



Professional, Reliable, & Versatile Mobile Coolers / Freezers

Introducing our innovative mobile cold storage solutions, engineered and designed to meet your specific cooling and freezing needs. Whether you're in the food industry, pharmaceuticals, or event management, our units offer unparalleled performance and flexibility.

Why Choose Everidge Mobile Cold Storage Solutions?

- **Configurations:** Standard 6'x8', 6'x12', 6'x16' with 30" or 48" heated threshold door. Custom configurations upon request.
- **Superior Technology:** Designed and engineered as cohesive units in our Virginia and Kansas plants. Our chassis are exclusively manufactured for Everidge. The refrigeration system has a digitally adjustable range of 0° to 50° for temperature holding.
- **Durability:** Constructed with high-quality materials to withstand various environmental conditions while maintaining reliability.
- **Safety Torsion System:** Incorporates the structure and chassis into a cohesive unit. It provides torsional rigidity and resistance to shear stress around the total perimeter of the unit.

Buy
Or
Finance

Mobile Units - Dimensions

Rear dimensions the same for all models.

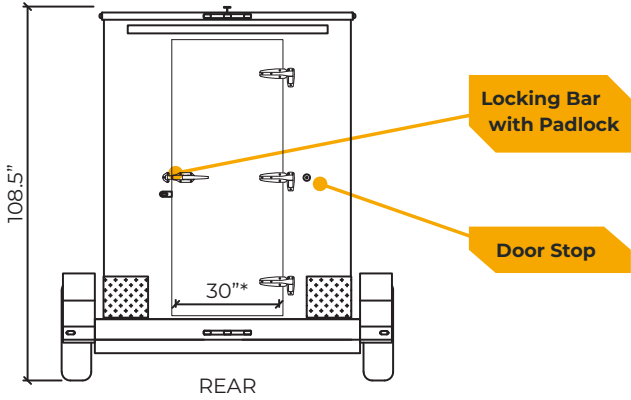

*30" or 48" Standard Door Size

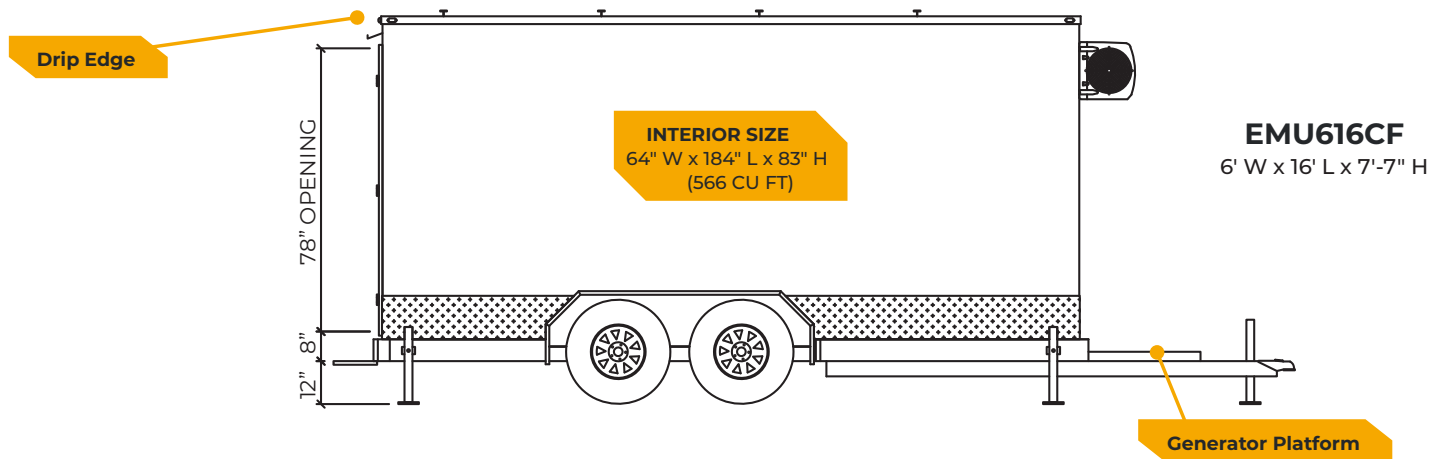
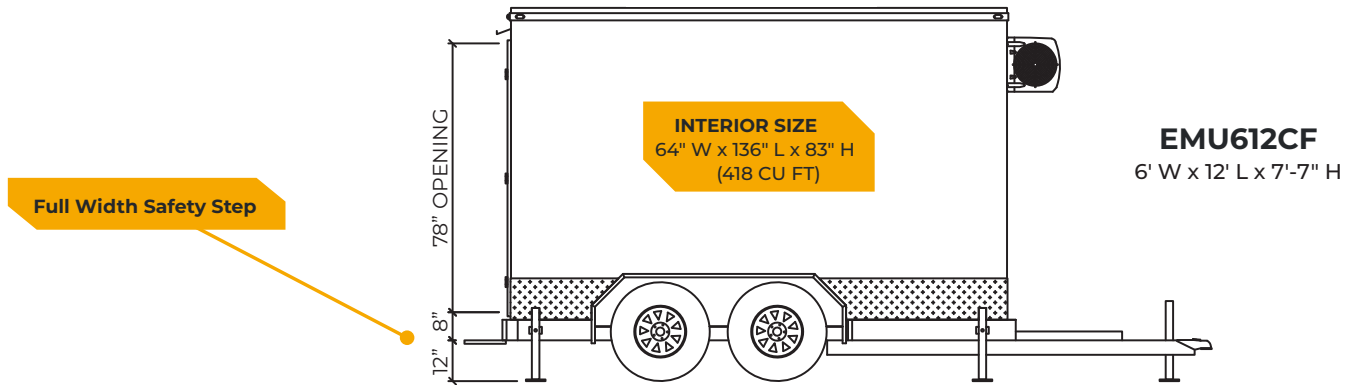
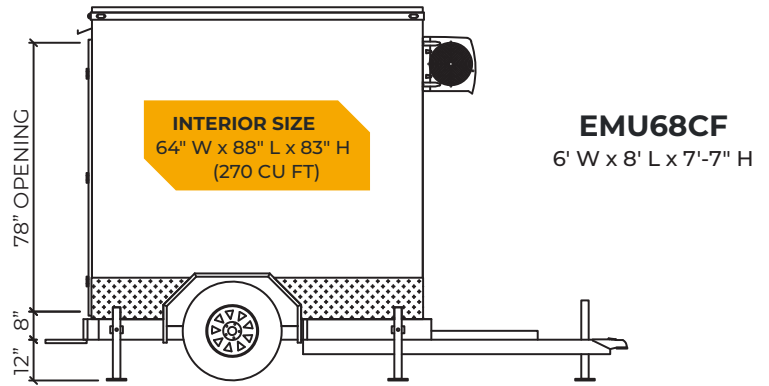

Contact your Everidge Dealer or Sales Representative today for more information!



CROWNTONKA[®] ICS[®] LOTEMP DOORS[®] PREPRITE[®] SMARTRITE[®] THERMALRITE[®]

Proud to be family-owned.

Walk-In Coolers/Freezers • Environmental Chambers • Restoration & Replacement Doors • Blast Chillers • Parts, Service & Warranty • Construction Services
15600 37th Ave N • Suite 100 • Plymouth, Minnesota 55446 • 888-227-1629 • Everidge.com • info@everidge.com • EV5059-1 • ©2025 Everidge, Inc.

All specifications are subject to change without advance notice.